

DEFECTOVISION® IR

EXPERIENCE A NEW DIMENSION IN BILLET TESTING

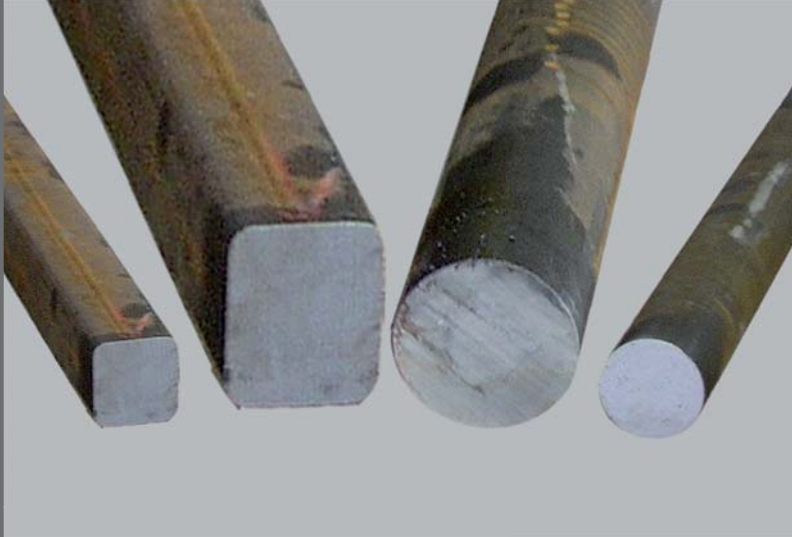

APPLICATION:

- ▶ Testing of round and square steel billets with hot-rolled surface
- ▶ Size range: 50 to 220 mm diameter or edge length

TECHNICAL DATA:

- ▶ Defect type: Longitudinal surface defects
- ▶ Defect detection: Test defects with a depth from 200 μm
- ▶ Transportation speed: Up to 1.5 m/s

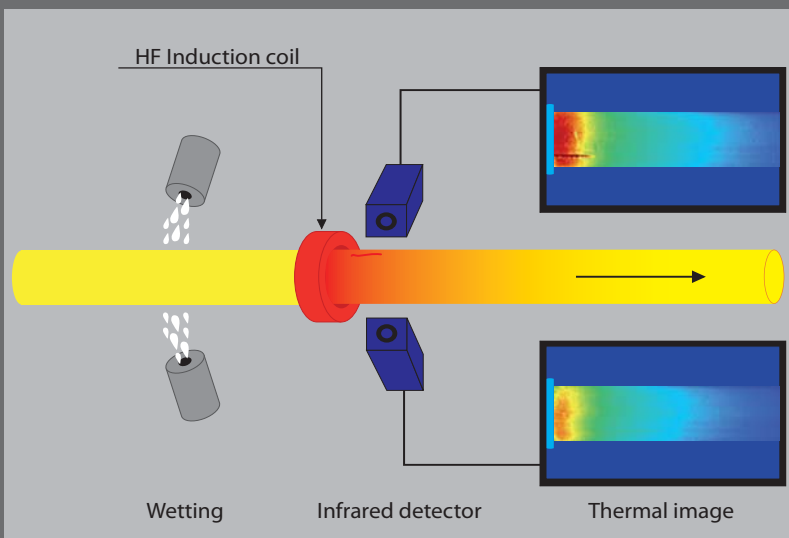
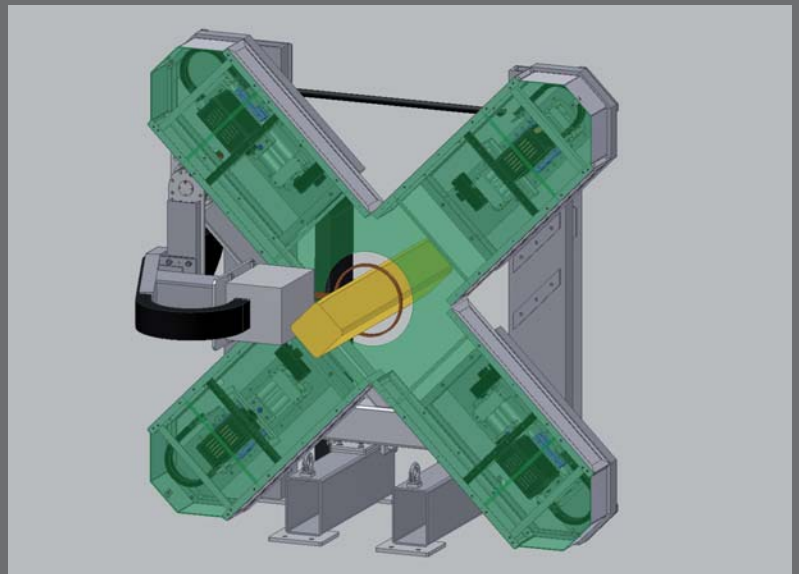

TECHNOLOGY

- ▶ Active thermography
- ▶ Defect activation by inductive heating
- ▶ Defect detection by state-of-the-art infrared detectors
- ▶ Signal evaluation by innovative software algorithms